

VSUN

Innovative & Smart



VSUN Crystalline Silicon PV Module Products Installation Manual

**Add: Lot III-Dong Vang Area, Dinh Tram Industrial Zone, Hoang Ninh Commune, Viet Yen District,
230000 Bac Giang Province, VIETNAM**

PC: 230000

Tel: 02403.566.688

E-mail: vsun@vietnamsunergy.com

Web: vsun-solar.com

Table of Contents

1 General Information	1
2 Disclaimer of Liability	1
3 Safety Precaution	2
3.1 General Safety	2
3.2 Handling Safety	2
3.3 Installation Safety	3
4 Product Identification	4
5 Electrical Property Parameters of Modules	5
6 Installation Instructions.	5
6.1 Installation Environment	5
6.2 Selection of Mounting Structure	6
6.3 Three kinds of Mounting	6
6.4 Two Installation Methods.	8
7 Electrical Installation	12
7.1 General With Regard to Electrical Installation	12
7.2 Grounding	12
8 Maintenance and Care	13
9 PV recycling	14

Crystalline Silicon PV Module Products Installation Manual

(Version: 2020.01)

1 General Information

This manual contains information regarding the installation and safe handling of the photovoltaic module (hereafter is referred to as “module”) which are produced by VIETNAM SUNERGY JOINT STOCK CPMPANY (hereinafter is referred to as “VSUN”).

Installers must read and understand the manual before installation. Any questions, please contact the sales or customer service personnel of VSUN for further explanations. The installer should conform to all safety precautions in the manual and local laws & regulations when installing module; before installing a solar photovoltaic system, installers should become familiar with the mechanical and electrical requirement for such a system. VSUN has the right to refuse to compensate for the product damage due to construction or design defects of the solar photovoltaic system.

Keep this manual in a safe place for future reference (care and maintenance) and in case of sale or disposal of the modules.

2 Disclaimer of Liability

Customers shall strictly abide by the requirements of this manual when installing the modules of VSUN. If the conditions or methods of the installation, handling, use and maintenance of the customer are beyond the range specified in this manual and cause damage, VSUN does not assume responsibility for any loss, damage or expense thus caused.

No responsibility is assumed by VSUN for any infringement of patent right or other rights of third parties, which may result from the customer’s use of the VSUN’s modules. No patent license or patent rights is granted to customer, express or implied, due to its use of VSUN’s modules.

The information in this manual is based on VSUN’s best knowledge and experience and is believed to be reliable; but such information including product specification (without limitations) and suggestions do not specifications, or product information without prior notice.

Notification is needed while the the modules are reinstalling.

3 Safety Precaution

3.1 General Safety

- ✚ When installing the modules, it should be abided by the relevant local laws and regulations. It is need to obtain the required certificates in advance when necessary, such as the building permit.
- ✚ Installing solar photovoltaic systems require specialized skills and knowledge. Installation should be performed only by qualified persons. Installers should assume the risk of all injuries that might occur during installation, such as electric shock.
- ✚ Photovoltaic modules are designed for outdoor use. Modules may be mounted on ground, rooftops, vehicles or boats. Proper design of support structures is the responsibility of the system designers or installers. Mounting holes or clamp range and numbers suggested in this manual shall be used.
- ✚ A single module may produce the direct current (hereafter is referred to as DC) voltage of above 30V in direct sunlight and it is extremely dangerous to contact it. Do not touch or lean on an operating module.
- ✚ Do not disconnect under load or apply paint or adhesive to module surface.
- ✚ Keep all electrical contacts clean and dry. Do not change the wiring of the bypass diodes. Do not disassemble the modules or remove any attached nameplates or components from the modules.
- ✚ Do not use mirrors or other magnifiers to artificially concentrate sunlight on the modules. Do not expose the backside of modules directly to sunlight for a long time.
- ✚ Modules should store in a dry and ventilated environment. In the storage and handling process, in case of inclement weather (rain, snow, wind, etc.), materials such as plastic film and waterproof cloth need to be covered on the packing boxes.
- ✚ During normal work, materials such as plastic film and waterproof cloth are forbidden to be covered on the glass surfaces of modules.
- ✚ Unpack the modules with packing box when they are moving on the ground. Unpacking directly when the modules are superposed is forbidden.

3.2 Handling Safety

- ✚ Keep children and unauthorized persons away from the modules while transporting and installing

them. Improper transportation and placing may lead to glass breakage or power loss of the modules, resulting in the loss of the use value of modules.

- ✚ Handle modules with care. Lift and put down modules gently. Do not drop modules or drop objects on the modules. Pay special attention not to collide, scratch or press the module backside when transporting and installing the modules. The double glass module should be handled more carefully. Non-slip gloves are required when handling and during installation.
- ✚ It is forbidden to pull the junction box or cables when carry or lift the modules. Carry a module by its edges with two or more persons. Increasing one or two persons lift up the middle of the panel is necessary for Non-frame module.
- ✚ Do not stack the modules for transportation. Do not set the modules down on any hard surface, which maybe cause the cells broken.
- ✚ To avoid module damage, do not place heavy objects or tools on the modules, and do not stand or step on the modules.
- ✚ Inappropriate transport and installation may damage the module. Control the vehicle speed when the road condition is relatively poor.

3.3 Installation Safety

- ✚ Abide by the safety regulations for all other components used in the system, including wiring and cables, connectors, solar charge controller, inverters, storage batteries, etc. Use suitable equipment, connectors, wiring and mounting system for a PV system. Use the same type modules and ensure color grade consistent as far as possible in one system.
- ✚ Do not install or handle the modules when they are wet or during strong wind.
- ✚ Modules are constructed with tempered glass, which shall be handled with care. Improper operations may cause the tempered glass breakage. If the front glass is broken or if the backsheet is burned-out, contact with any module surface or the aluminum frame can produce electrical shock, particularly when the module is wet. Broken or damaged modules must be disposed properly.
- ✚ The maximum system voltage is indicated in the nameplate. During the system installation, the maximum open circuit voltage in series cannot exceed the maximum system voltage.

- ✚ Completely cover the module with an opaque material during installation to keep electricity from being generated. Under high temperature and high humidity environment, the material component of glass surface will not cause pollution, such as rubber glue splotch, oil, printing and dyeing, etc. Contact the glass surface with bare hand is prohibited.
- ✚ Do not place the glass surface or the backsheet surface of the modules down directly on the ground in the installation site (mud, sandy land, grassland, Gobi, etc.).
- ✚ Modules not used up should be stored and transported after packaging in accordance with the manufacturer's packaging.
- ✚ Do not wear metallic rings, watchbands, ear, nose, lip rings or other metallic devices while installing or troubleshooting photovoltaic systems. Use insulated tools that are approved for working on electrical installations and always keep them dry.
- ✚ The triangle hole punched on the backside frame of the module is the drain hole which cannot be blocked.
- ✚ During modules interconnection, guarantee to fix the connecting cables to the mounting system, so as to restrict the swing amplitude of the slack part of the wire.
- ✚ Conform to the allowable minimum bending radius of the wire (Definition: Minimum bending radius is 12 times of the wire's external diameter). Concerning to the wire with junction box, the allowable minimum bending radius is 12 times of OD (diameter). About the other minimum bending radius, please seek help from professional installer.
- ✚ Always protect the wire with conduit where animals or children can touch it.
- ✚ Please use the connector which is specially designed for photovoltaic system and assemble it with the tools recommended or specified by the manufacturer. In case that the connector applicable to the solar photovoltaic system is required, please contact the local supplier.
- ✚ Make sure that the polarity is correct when connecting the module with inverter, storage battery or combiner box to avoid the unrecoverable damage of bypass diodes in the modules due to incorrect polarity.

4 Product Identification

Each module has labels providing the following information:

- ✚ Nameplate: Describes the product type, rated power, rated current, rated voltage, open circuit voltage,

short circuit current, all are measured at STC; weight, dimension, maximum system voltage and the fuse rating are all shown on the nameplate.

- ✚ Barcode: Each module has a unique serial number. It contains the relevant production information of the module.

5 Electrical Property Parameters of Modules

- ✚ Under Standard Test Conditions (1000W/m², AM1.5 and 25°C (77°F)) the electric characteristics, including I_{sc} and V_{oc}, the deviation between the measured value and nominal value is within ±3.5%.
- ✚ Under normal outdoor conditions, a module is likely to produce different current and voltage than the values measured under STC in the specification of VSUN module products. Therefore, when determining the parameters related to the power output of the module, for example, nominal voltage, conductor capacity, fuse capacity and controller capacity, etc., refer to the values of short-circuit current and open circuit voltage of the modules, and take 125% of those values during design and installation.
- ✚ The maximum nominal voltage for all module series is 1000V or 1500V according to IEC/UL standards. Please check it according to the nameplate.

6 Installation Instructions

6.1 Installation Environment

- ✚ In most applications, PV modules should be installed in a location where they will receive maximum sunlight throughout the year.
- ✚ The module shall be installed in the place where the sunshine is adequate. The module should not be shaded at any time during its operation. During installation, the module surface shall not be partly shaded by clothes, tools, packaging materials, etc.
- ✚ Install the module in well ventilated place and guarantee that adequate natural air heat dissipation channels are provided at the back and sides of the module to ensure that the heat generated during operation is radiated in time.
- ✚ Never place the module in locations where flammable gases may be easily generated or collected.
- ✚ VSUN suggests installing the module in dry areas where the climate is moderate. The modules shall not be allowed to be mounted in the site with excessive hail, snow, sand, smoke dust and so on.
- ✚ VSUN's modules have passed the certification of IEC 61701 with 5% NaCl. But corrosion probably

occurs in the contact place between modules and mounting brackets. Without the approval of VSUN, modules should not be installed in the site which is within 500m away from the sea.

- ✚ Modules connected in series should be at the same tilt and azimuth. Differing orientations or angles may cause a loss of power output due to differing amount of sunlight exposure for each module. Typically, the optimal tilt for a module is roughly the same as the installation location.
- ✚ When unpacking the modules should be installed as soon as possible and connected to the combiner box to avoid connection failure. Protecting covers are advised to be used if modules are installed in the site with heavy sand or salt mist.

6.2 Selection of Mounting Structure

- ✚ Always conform to the instruction manual and safety rules attached to the mounting system.
- ✚ The entire PV system consisting of modules must be able to withstand anticipated mechanical pressure which comes from local wind force, snow, etc.
- ✚ Drilling holes on the surface of module glass may void the warranty.
- ✚ Drilling additional mounting holes on module frames may void the warranty.
- ✚ The mounting system structure must be made of durable, corrosion-resistant and UV-resistant materials.
- ✚ Forces generated during thermal expansion and contraction of the mounting system structure shall not influence the performance and use of the module.
- ✚ The bearing surface of the mounting structure must be smooth without any twist or deformation, and the connected support frames shall be at the same height.

6.3 Three kinds of Mounting

(A) Roof Mounting

- ✚ It is necessary to provide a special support frame for the roof mounting. When installing a module on a roof or building, ensure that it is securely fastened and cannot fall or be damaged as a result of strong winds or heavy snows. During roof mounting, check the building codes being used to ensure that the building and its structure where the module is installed have adequate bearing capacity. The roof needs to be penetrated during module installation and fixing shall be sealed to avoid rainwater seepage.
- ✚ To be suitable for operation, reduce steam condensation and facilitate the ventilation & heat

dissipation of the module during tile installation, the module shall be parallel to the wall or roof surface of the building, and the clearance between module and surface of the wall or roof shall be at least 115mm to prevent wiring damage and to allow air circulation, ventilation and heat dissipation behind the module. During stacking type installation, the module shall be installed on the fire-resistant roof. The modules Fire Resistance Rated Class of the modules is Class C, and the modules are suitable for mounting on an above Class A roof. Do not install modules on a roof or building during strong winds.

(B) Pole Mounting

- ✚ When installing a module on a pole, choose a pole and module mounting structure that will withstand the anticipated wind power of the local area. The support rod must be constructed on a solid foundation.

(C) Ground Mounting

- ✚ Select the height of the mounting system to prevent the lowest edge of the module from being covered by snow for a long time in winter in areas that experience heavy snowfalls. The module shall be installed on the mounting system with appropriate height instead of being directly laid on the ground. In addition, assure the lowest portion of the module is placed high enough, so that it is not shaded by plants or trees, and the module is not damaged by sand and stone driven by wind, or the module surface is not shaded by the mud splashed by rain water.

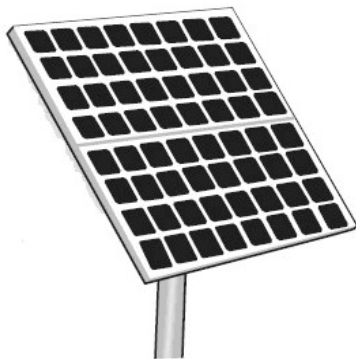

FIG 1 Pole mounting



FIG 2 Ground mounting

- ✚ Notice: For the roof system installed in the area that ever experienced relatively heavy snowfall or snow cover, the customer shall reinforce the mounting system at the lower frame of the module, in order to prevent the lower frame from being pressed and damaged by the falling snow, and avoid the module damage due to melt snow freezing in daytime. VSUN suggests to selecting the support reinforcing mechanism shown in Figure 3.

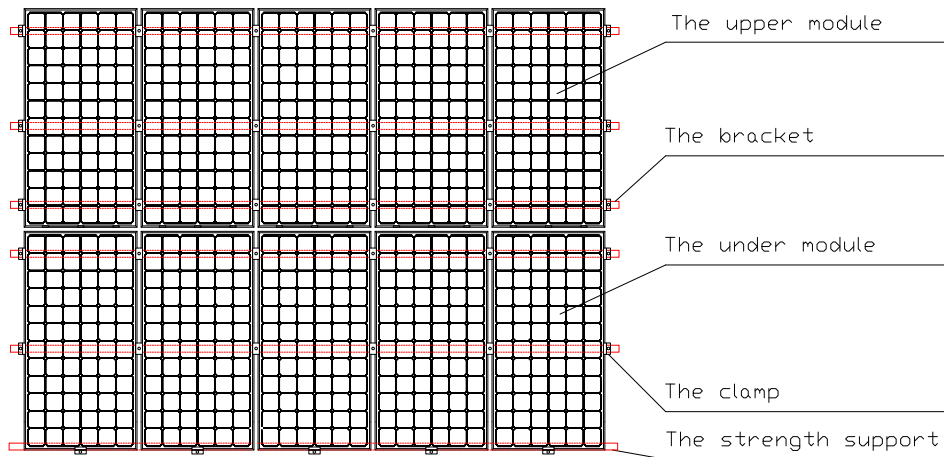

FIG 3 Schematic diagram of reinforcement mounting of module

6.4 Three Installation Methods

- Concerning to modules with frame (including double glass module). Modules can be installed on the frame using mounting holes or clamps. Modules must be installed according to the following examples. Not mounting the modules according to these instructions may void the warranty.
- The modules have been evaluated by IEC61215 standard for mechanical load design (testing load). According to the requirements of IEC61215, 1.5 times of safety parameter should be considered while calculating corresponding maximal design load.
- Normal load is suitable for the most condition of environment: the obverse side can sustain 5400Pa static load, the reverse side can sustain 2400 Pa static load.
According to the requirements of IEC61215, in regard to dynamic load, like gust, 3 times of safety factor should be considered. That is to say, 800 Pa dynamic wind load in the condition of gust equals 2400 Pa static wind load (wind speed ≤ 130 km/h).
- The mounting system and other various goods & materials required (such as screw) shall be made of durable, corrosion-resistant and UV-resistant materials.

6.4.1 Screw fitting:

- Using corrosion-proof screws (M8) in the existing installing holes in the module frame. The range of torque is from 16-20N.M while tightening the screw.
- Do not attempt to drill holes in the glass surface or additional mounting.
- The frame of each module has 4 mounting holes used to secure. As shown in Figure 4, four

mounting holes are needed in normal. Regarding to large modules of type 72, eight mounting holes are needed or in the condition of sustaining higher load.

- ✚ The module frame must be attached to the mounting system using M8 stainless steel hardware together with spring washers and flat washers in four places symmetrical on the module, as shown in Figure 5.

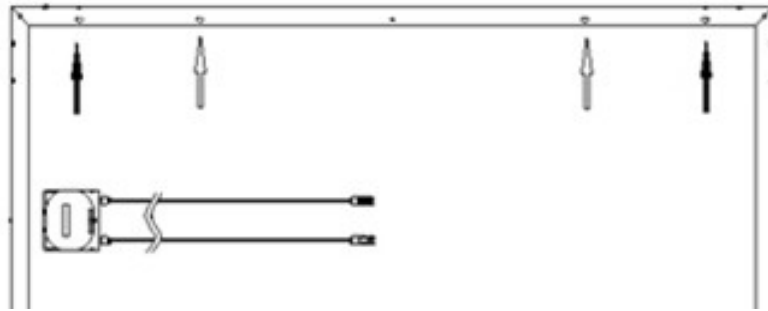

FIG 4 Mounting holes

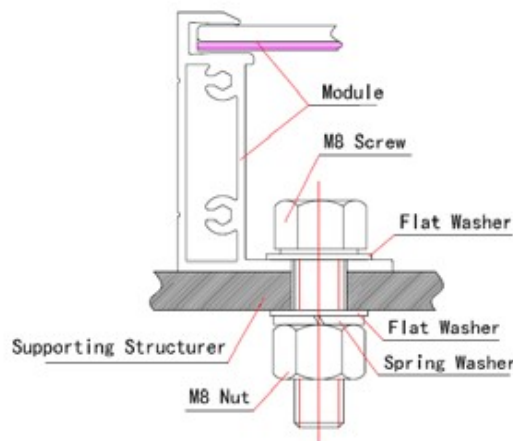

FIG 5 Screw fitting method

6.4.2 Clamp fitting (frame module):

- ✚ Using suitable module clamps on the side of the module frame to mount the modules, as shown in FIG 6. The thickness of the clamp should be no less than 3mm, the length should be no less than 40mm and the length of the overlap should be no less than 5mm.
- ✚ At least 4 clamps should be used in each module, and install 2 clamps on each side.
- ✚ Modules should be mounted by screw, flat washer and spring washer on mounting rack. The clamp should be mounted in a symmetric position respect to the center, as shown in FIG. 6. The torque should be determined by the mechanical design standard of the screw. For instance, M8--16-20N.m.
- ✚ The clamp can not be attached with the front glass, and keep the shape of frame while mounting.

- ✚ Avoid shading effects created by clamps on the cells of modules' obverse side.
- ✚ If the customer has special clamping and installation schemes which are not included in this manual, please contact the local dealer for professional support.
- ✚ If heavy snowfall, relatively large snow load or large wind pressure exist in the module installation area, VSUN suggests the customer to ask help from professional installer to improve the bearing capacity of the whole PV system.

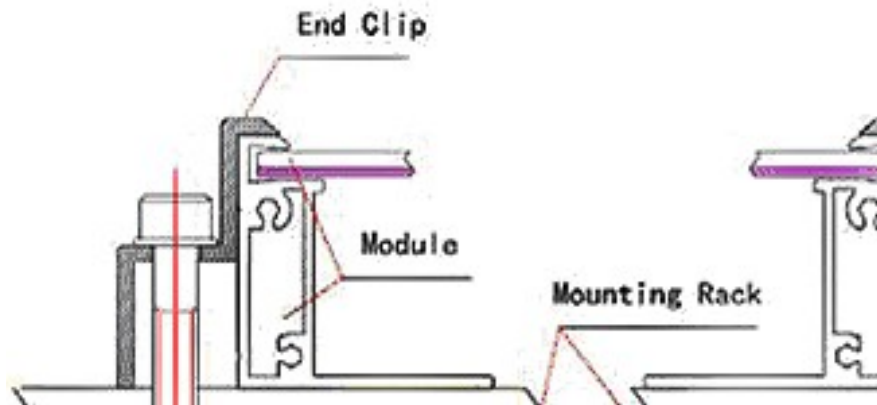

FIG 6 Clamping mounting method

Short Side	Long Side
Back static load $\leq 2000\text{Pa}$ 、Front static load $\leq 2000\text{Pa}$: $0 \leq S \leq (W/4)$	Back static load $\leq 2000\text{Pa}$ 、Front static load $\leq 2000\text{Pa}$: $0 \leq S \leq (W/4)$
Back static load $\leq 2400\text{Pa}$ 、Front static load $\leq 2400\text{Pa}$: $(W/20) \leq S \leq (W/5)$	Front static load $\leq 2400\text{Pa}$ 、Back static load $\leq 2400\text{Pa}$: $(L/8) \leq S \leq (L/4)$
----	Front static load $\leq 5400\text{Pa}$ 、Back static load $\leq 2400\text{Pa}$: $(L/4-50) \leq S \leq (L/4+50)$

6.4.3 NEXTracker Mounting System

- If VSUN modules will be mounted on NEXTracker system at 400mm short rail. The special mounting holes should be designed as FIG. 7.

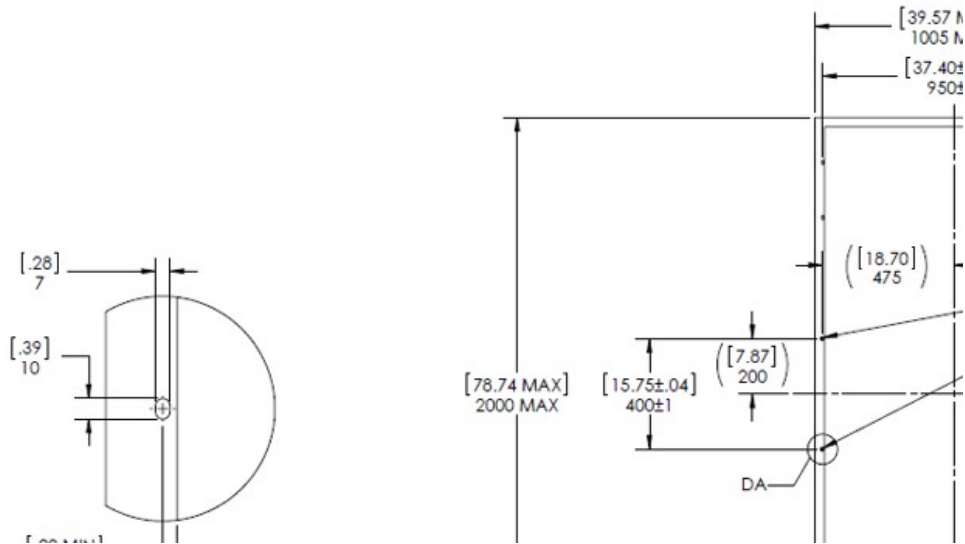

FIG 7. NEXTracker mounting holes at 400mm short rails

- The maximum pressure rating of front side and back side is 2400Pa for VSUN standard modules with 40mm height frame.
- Please confirm with NEXTracker supplier to obtain the detailed information of mounting system.

* NOTES:

VSUN's limited warranty will be void in cases where improper clamps or installation methods deviating from this manual are used. When installing inter-modules or end type clamps, take measures so as:

- Not to bend the module frame.
- The clips must only fix the modules by the contact with the frame. Do not allow contact between clip and glass.
- Not to damage the surface of the frame.
- When mounting, be sure that the module's drain holes are not blocked. For matters concerning installation not mentioned in this section, contact the local dealer for professional support.

7 Electrical Installation

7.1 General With Regard to Electrical Installation

- ✚ Try to use the modules with the same configuration in the same photovoltaic system. If the modules are connected in series, the total voltage is the sum of voltages of all the modules, and the maximum number of the series modules $(N) = V_{\max}(\text{System}) / [V_{oc}(\text{at STC})]$.
- ✚ If the system requires the installation of high current, several photovoltaic modules can be connected in parallel, and total current is the sum of current of all the modules. The maximum number of the parallel module strings $(N) = I_{\max}(\text{fuse rating}) / I_{sc}$.
- ✚ When connecting modules, make sure that the connectors of the same series module shall come from the same manufacturer or totally be compatible with each others, and the same requirements shall go to the connection terminals of module end and system end, for the connectors of the different manufacturers may not be compatible with each others, which easily leads to mismatch risk.
- ✚ The cross section area and connector capacity of the cable selected must satisfy the maximum short-circuit current of the system (It is recommended that the cross section area of the cable used for the single module is 4mm^2 , and the rated current of the connector is not less than 30A. Please note that the upper temperature limit of the cable and connector is 85°C and 105°C respectively).
- ✚ When installing the module, place the end with the junction box up and try to avoid the rain.
- ✚ Do not carry out installation in rainy weather for humidity will void the insulation protection, thus causing safety accidents.

7.2 Grounding

- ✚ All module frames and mounting racks must be properly grounded. As shown in FIG 9-a. The grounding wire must be properly fastened to the module frame to assure good electrical contact. Use the recommended type, or an equivalent, connector for this wire.
- ✚ If the mount system is made of metal, the surface of the structure must be electroplated and have excellent conductivity.
- ✚ Proper grounding is achieved by connecting the module frame(s) and structural members contiguously using a suitable grounding conductor.
- ✚ The grounding conductor must then make a connection to earth using a suitable earth ground electrode. Recommend to use the ground wire accessories (lugs) connected to ground Cable. Welding

ground cable to the jack of lugs, and then with the M4 screws inserted into the wiring nose ring and to the grounding hole of the module frame, fastening with nuts. Star spring washers should be used to prevent the screws from loosening and lead to poor grounding (as shown in FIG8).

- ✚ The module frame to EARTH resistance must be less than 4 ohm.
- ✚ VSUN recommends to install modules at the temperature from -40°C to 50°C , and the relative humidity should be less than 85RH%. Besides, the ultimate temperature of working is from -40°C to 85°C . If the modules are used in high-temperature and high-humidity environment, VSUN requires the customer to ground the negative end of the inverter (as shown in FIG9). Offset Box or PID Box can also be used instead to apply a positive voltage to the module arrays at night to avoid PID.

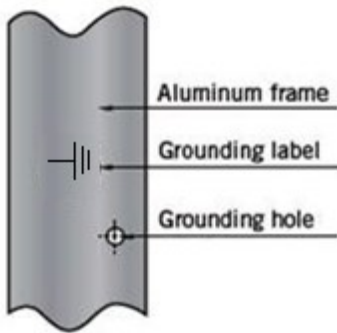

FIG 8-a Grounding hole

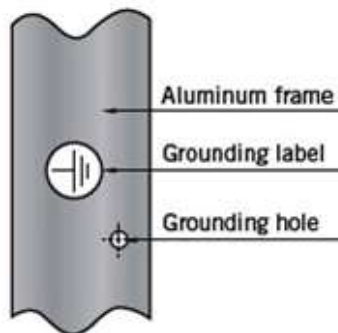

FIG 8-b Grounding method

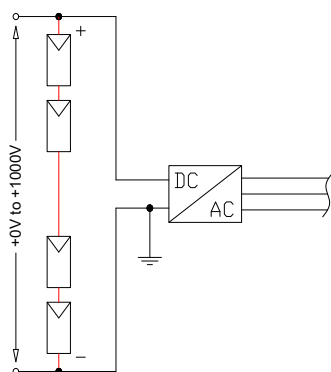
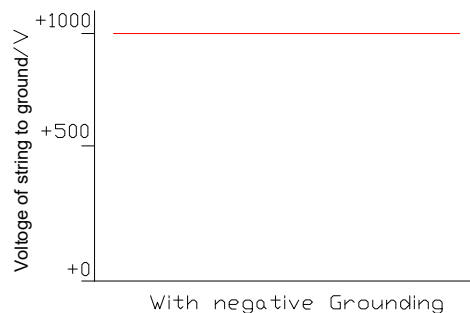

FIG 9 Schematic diagram for grounding potential of the inverter



8 Maintenance and Care

- ✚ Clean the glass surface on a regular basis. Avoid the hotspot risk caused by ornithocopros, leaves and dead insects covering the glass surface.
- ✚ In general, use water and a soft sponge or cloth for cleaning. A mild, non-abrasive cleaning agent can

be used to remove stubborn dirt.

- ✚ Avoid pressing part of the module hard during cleaning, such as washing modules by water torch. The strength on the module is less than 690kPa, because pressing hard may cause glass deformation, cell damage and service life reduction. Remove the snow covered on the module in time to avoid the module damage caused by long-term accumulation of snow cover and freezing of melted snow. Remove plants and sundries surrounding the modules in time to stop them from shading modules and influencing the property.
- ✚ Examine the PV module(s) for signs of deterioration. Check all wiring for possible rodent damage, weathering and that all connections are tight and corrosion free. Check electrical leakage to ground. Check fixing screws and mounting brackets, adjust and tighten as necessary.
- ✚ Never clean the electrical connectors including cable, junction box and connector with the cleaning agents that contain organic matters such as alkane.
- ✚ If any problem arises, have it investigated by a competent specialist.

* If the maintenance measures are not included in this manual, please contact the local dealer for professional support.

9 PV recycling

Do not dispose the PV module as unsorted municipal waste in accordance with WEEE Directive (Waste from Electrical and Electronic Equipment Directive), EN50419 and all the other applicable laws.



-END